

SINGLE POINT TRAILER SUSPENSION

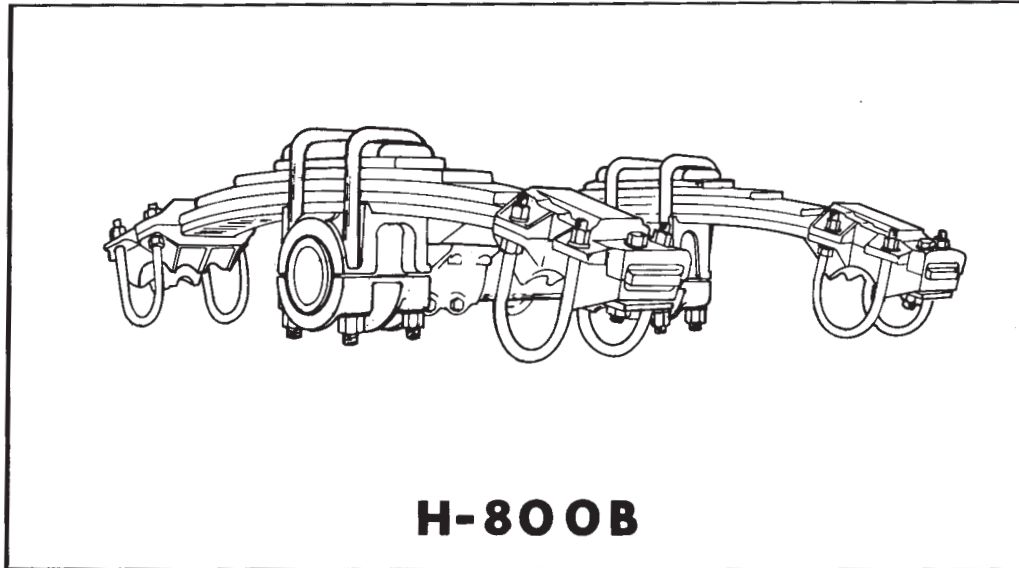

FEATURES OF THIS MODEL

1. A single point suspension specially designed for off road operations, such as logging or dump.
2. Available in a broad range of variations to suit almost any mounting requirement. The standard trunnion mounting is shown, with optional (spring underslung) trunnion mounting available.
3. A broad range of load capacities are available. H-800B-36 for up to 36,000 pound capacity, H-800B-42 for 42,000 pound capacity, H-800B-50 for 50,000 pound capacity and H-800B-60 for up to 60,000 pound loads.
4. Springs are kept in alignment by the use of spring guides on the trunnion casting.
5. Optional 2" thick spacers, trunnion hangers in three heights, and heavy duty mounting brackets are available.
6. Spring end boxes have a built-in bump out area for maximum oscillation protection.
7. The industry's first single point suspension with adjustable alignment of axles. When alignment is completed, the adjustment plate is simply welded in place to prevent future misalignment.
8. The trunnion rubber bushing is 100% rubber and is pre-loaded at assembly to insure live action of the rubber. Greater flexibility, easier ride and reduced wear are the results of this feature.
9. Maintenance and replacement of the trunnion bushing is facilitated by the use of a split trunnion casting.
10. The unit is completely rubber bushed, with the use of rubber pads, above and below the spring leaves in the "axle boxes." A bonded bushing is utilized where the 1" diameter retainer bolt is used in the spring and axle box connection. This feature reduces wear and prolongs the life of all components.
11. This unit is prime painted ready for installation.

IMPORTANT: HSB-52,R-11/73 supersedes all previously issued material relating to the H-800 suspension series, its installation and usage. Usage of outdated material can result in improper installation of suspension.

CONTENTS OF THIS SECTION

1. MODEL FEATURES AND PHOTO OF UNIT
2. NOTES
3. H-800B-36
4. H-800B-42
5. H-800B-50
6. H-800B-60
7. INSTALLATION INSTRUCTIONS
8. INSTALLATION INSTRUCTIONS

INSTRUCTIONS

Determine suspension requirements, i.e., load capacity, axle size, and mounting height. The following pages show the basic units available and the standard variations of those units.

Unless otherwise specified, all units will be shipped with 38" spring centers, trunnion underslung, axles overslung, preassembled at our factory with 2½" trunnion hangers. For engineering assistance or information not listed in this section, contact Hutchens Industries, Inc., Sales Engineering Department.

NOTES

1. When 36" spring centers are specified, trunnion bracket will be reversed so that flat side faces out. Trunnion bracket center to center dimension will be maintained at 20 1/8" unless otherwise specified.
2. A mounting bracket is available which facilitates installation on some applications. When the optional mounting bracket is used, add 10" to the height shown on the mounting height chart. Specify 855-00 mounting bracket.
3. Maximum and minimum axle spacing dimensions represent the adjustment available in the axle boxes. Be certain that axles are in alignment with the king pin and are parallel before welding adjustment plates. Adjustment plates must be welded prior to operating the unit. (see installation instructions)
4. Mounting heights shown are the vertical distance from the top of the trunnion hanger to the center line of the axles. Dimensions shown are for springs in a completely unladen condition.
5. The following are the recommended "S" camshaft locations: (a) Standard axle mounting-rear horizontal center line or 22½° down. (b) Underslung axle mounting-rear horizontal center line.
6. See parts list for springs that will be furnished with optional (underslung) trunnion mounting.
7. For installation instructions see pages 7 & 8.

MOUNTING HEIGHT

Trunnion	Hanger	H-800B-36		H-800B-42		H-800B-50		H-800B-60	
		OS	US	OS	US	OS	US	OS	US
Standard	2½"	4½	-3¼	4¾	-3½	5	-3½	5¼	-3½
	6½"	8½	¼	8¾	½	9	½	9¼	½
	8½"	10½	1⅝	10¾	1⅞	11	1⅞	11¼	1⅞
Optional	2½"	15½	7⅞	16½	8¼	17½	9	19¼	10½
	6½"	19½	11⅞	20½	12¼	21½	13	23¼	14½
	8½"	21½	13⅞	22½	14¼	23⅜	15	25¼	16½

NOTE: Where underslung mounting heights are preceded by minus signs (-), centerline of axles is above top of standard 2½" trunnion hangers.

AXLE SPACING		
(dimensions shown are the maximum and minimum of adjustment)		
MODEL	UNDERSLUNG	OVERSLUNG
H-800B-36	53"--- 51¼"	48¼"--- 47"
H-800B-42	55¾"--- 54½"	51"--- 49¾"
H-800B-50	54½"--- 53¼"	51"--- 49¾"
H-800B-60	54½"--- 53¼"	53¼"--- 52"

H-800B-36

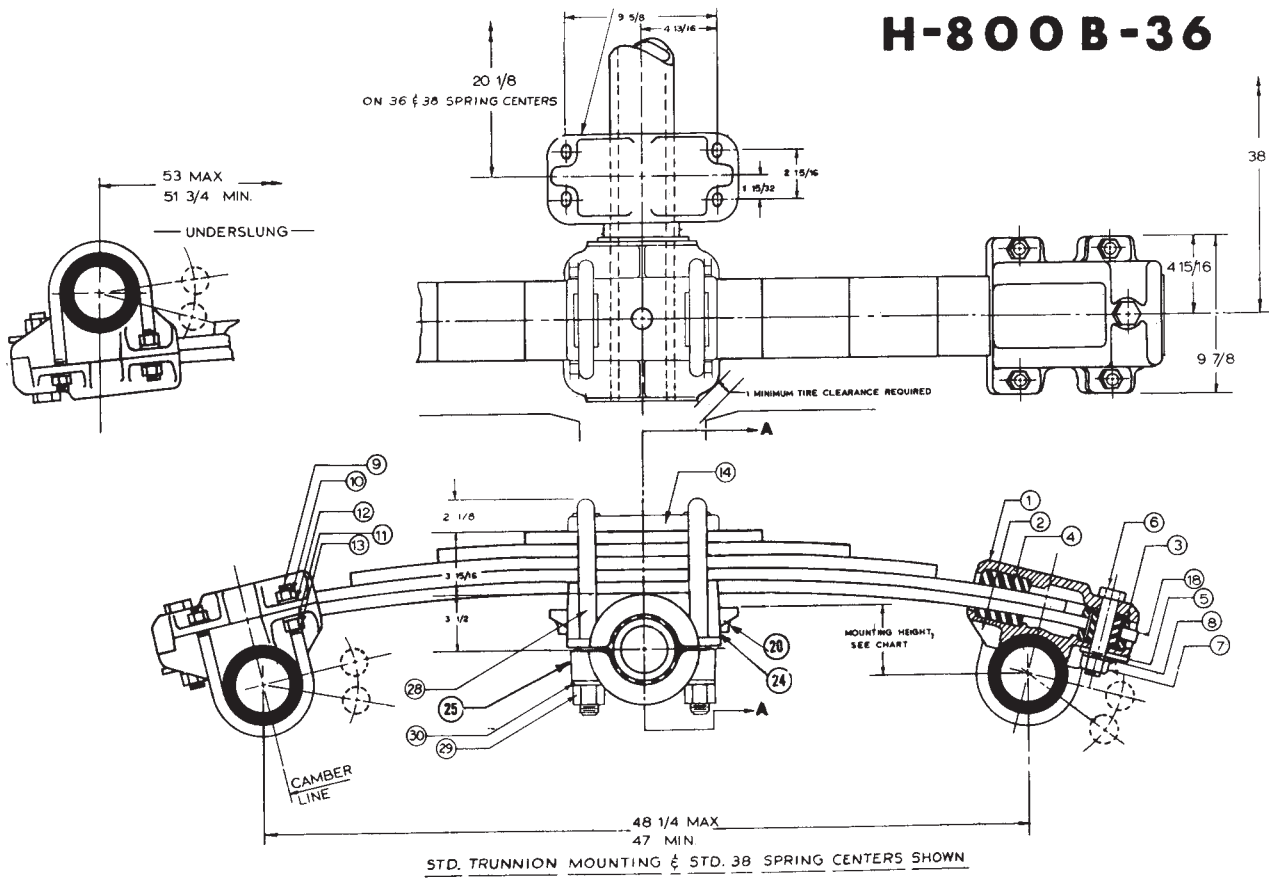

PARTS LIST

ITEM	NO.	DESCRIPTION	REQ.
1	811-01	Axle box upper half	4
2	812-00	Axle box lower half, 5 RD	4
3	813-00	Rubber pad with holes	8
4	814-00	Rubber pad without holes	8
5	816-00	Adjustment plate	4
6	719-03	Hex head bolt 1 - 14 x 5	4
7	736-00	Hex lock nut 1 - 14	4
8	9330-00	Lock washer 1 shakeproof	4
9	894-01	3/4 - 16 UNF, 5 RD x 8 1/4	8
10	841-00	Hex lock nut 3/4 - 16	16
11	843-00	Lock washer 3/4 medium spring	8
12	817-00	Washer 3/4 plain	16
13	842-00	Hex nut 3/4 - 16	8
14	9640-00	Top plate - cast, SQ U-bolt	2
15	511-00	Bolt - 3/4 - 10 UNC x 3 LG	4
16	531-00	Hex nut - 3/4 - 10 UNC - 28	4
17	541-00	Lock washer - 3/4	4
18	801-00	Spring ass'y 5 leaf	2
19	852-00	Spacer - trunnion hanger	
20	850-01	Trunnion hanger (std) 2 1/2	2
21	849-01	Trunnion hanger (opt) 6 1/2	
22	897-01	Trunnion hanger (opt) 8 1/2	
23	890-00	Rubber bushing - trunnion hub	2
24	891-00	Trunnion hub - upper half, std.	2
25	898-00	Trunnion hub - lower half, std.	2
26	893-01	Trunnion tube	1
27	895-00	Washer - 7 GA x 4 1/32 ID x 5 1/4 OD	2
28	9639-01	U-bolt - 1.067 dia, 5 1/8 SQ	4
29	836-00	Hex nut (high) 1 1/8 - 12	8
30	837-00	Washer 1 1/8 plain	8
31	892-00	Trunnion hub - upper half, opt.	
32	835-02	U-bolt - 1.067 dia, 5 7/8 RD x 13 3/4	4
33	820-00	Bottom plate	2
34	801-06	Spring 18,000 lb. OS & US, 5PL (opt)	

WHEN USING 852-00 SPACER, INSERT SPACER BETWEEN TRUNNION HANGER AND TRAILER BRACKET. WELD ALL AROUND SPACER TOP & BOTTOM.

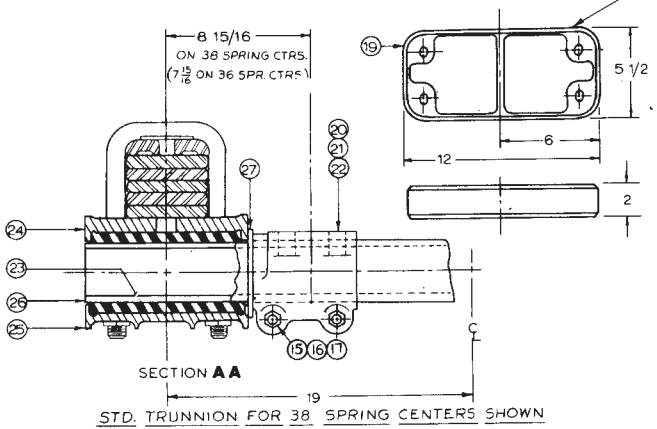

STD. TRUNNION FOR 38 SPRING CENTERS SHOWN

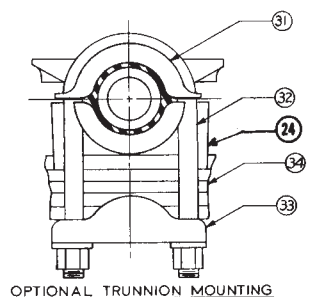

OPTIONAL TRUNNION MOUNTING

H-800B-42

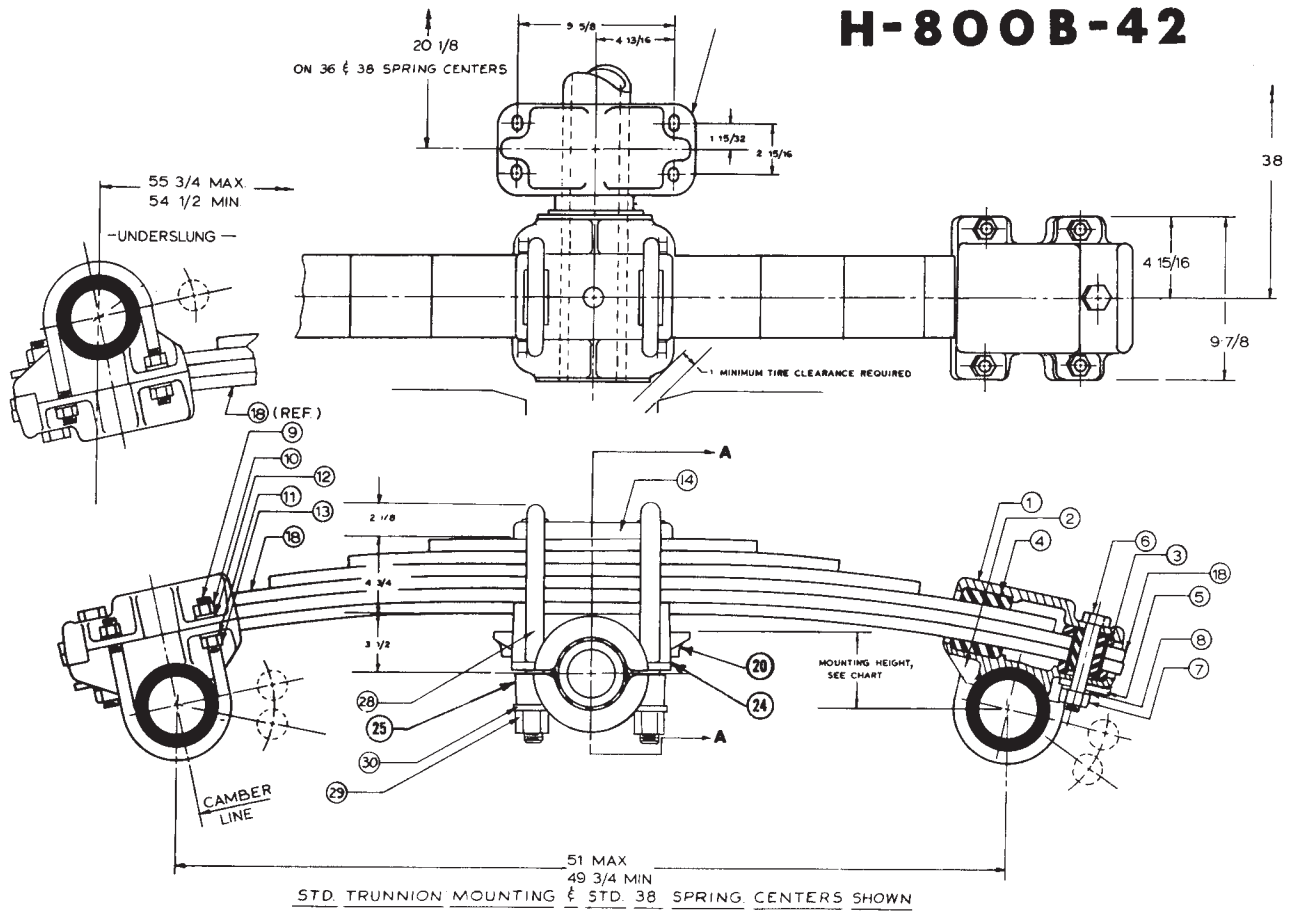

STD TRUNNION MOUNTING & STD. 38 SPRING CENTERS SHOWN

PARTS LIST

ITEM	NO.	DESCRIPTION	REQ.
1	815-01	Axle box upper half	4
2	812-00	Axle box lower half 5 RD	4
3	813-00	Rubber pad with holes	8
4	814-00	Rubber pad without holes	8
5	816-00	Adjustment plate	4
6	719-03	Hex head bolt 1 - 14 x 5 3/8	4
7	736-00	Hex lock nut 1 - 14	4
8	9330-00	Lock washer 1 shakeproof	4
9	894-01	3/4 - 16 UNF 5 RD x 8 1/4	8
10	841-00	Hex lock nut 3/4 - 16	16
11	843-00	Lock washer 3/4 medium spring	8
12	817-00	Washer 3/4 plain	16
13	842-00	Hex nut 3/4 - 16	8
14	9640-00	Top plate - cast, SQ U-bolt	2
15	511-00	Hex bolt - 3/4 - 10 UNC x 3 LG	4
16	531-00	Hex nut - 3/4 - 10 UNC - 2B	4
17	541-00	Lock washer - 3/4 zinc plated	4
18	888-00	Spring ass'y 6 leaf	2
19	852-00	Spacer - trunnion hanger	
20	850-01	Trunnion hanger (std) 2 1/2	2
21	849-01	Trunnion hanger (opt) 6 1/2	
22	897-01	Trunnion hanger (opt) 8 1/2	
23	890-00	Rubber bushing - trunnion hub	2
24	891-00	Trunnion hub - upper half, std.	2
25	898-00	Trunnion hub - lower half, std.	2
26	893-01	Trunnion tube	1
27	895-00	Washer - 7 GA x 4 1/32 ID x 5 1/2 OD	2
28	9639-02	U-bolt - 1.067 dia, 5 1/8 SQ	4
29	836-00	Hex nut (high) 1 1/8 - 12	8
30	837-00	Washer - 1 1/8 plain	8
31	892-00	Trunnion hub - upper half, opt.	
32	835-03	U-bolt - 1.067 dia, 5 7/8 RD x 14 5/8	4
33	820-00	Bottom plate	2
34	888-07	Spring - 21,000 lb, OS & US, 6PL (opt)	

WHEN USING 852-00 SPACER, INSERT SPACERS BETWEEN TRUNNION HANGER AND TRAILER BRACKET. WELD ALL AROUND SPACER TOP & BOTTOM.

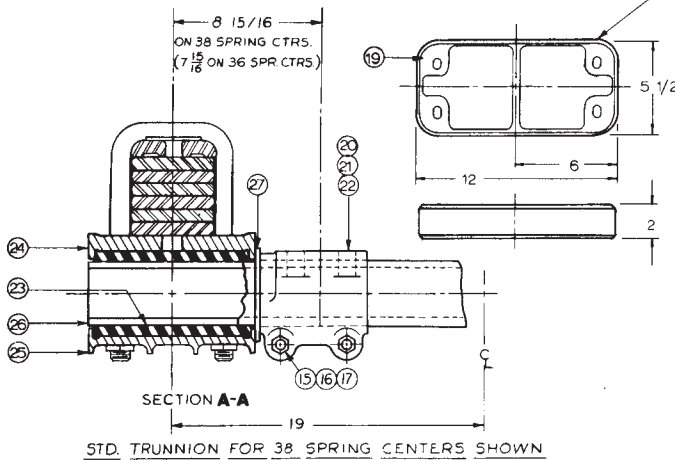

STD. TRUNNION FOR 38 SPRING CENTERS SHOWN

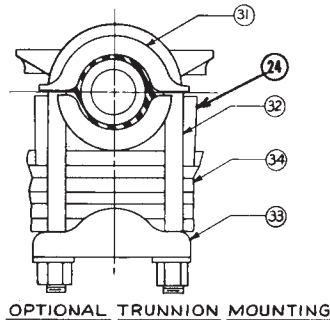

OPTIONAL TRUNNION MOUNTING

H-800B-50

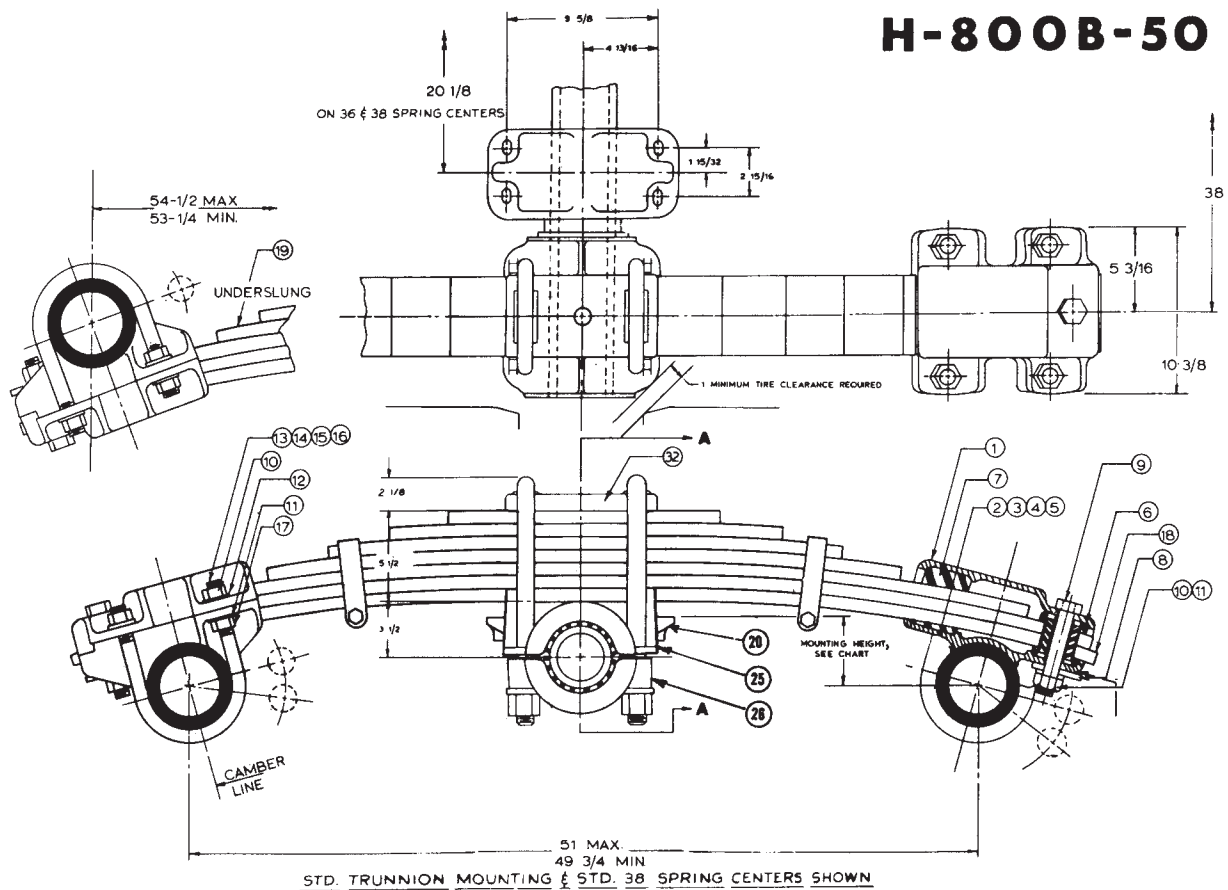

PARTS LIST

ITEM	NO.	DESCRIPTION	REQ.
1	805-01	Axle box - upper half	4
2	807-01	Axle box - lower half 5 RD	
3	807-02	Axle box - lower half 5 1/2 RD	4
4	807-03	Axle box - lower half 5 3/4 RD	
5	807-04	Axle box - lower half 6 RD	
6	813-00	Rubber pad with hole	8
7	814-00	Rubber pad without hole	8
8	816-00	Adjustment plate	4
9	719-03	Hex head bolt 1 - 14 x 5 3/8	4
10	736-00	Hex lock nut 1 - 14	20
11	9330-00	Lockwasher 1 shakeproof	12
12	774-01	Washer 1 plain	16
13	894-01	3/4 - 16 UNF 5 RD x 8 1/4	
14	840-02	U-bolt 1 dia, 5 1/2 RD x 9 3/8	8
15	840-03	U-bolt 1 dia, 5 3/4 RD x 9 5/8	
16	840-04	U-bolt 1 dia, 6 RD x 9 7/8	
17	870-00	Hex nut 1 - 14	8
18	847-00	Spring assembly - 7 leaf (std)	2
19	872-00	Spring assembly - 7 leaf US	
20	850-01	Trunnion hanger 2 1/2 high	2
21	849-01	Trunnion hanger 6 1/2 high	
22	897-01	Trunnion hanger 8 1/2 high	
23	852-00	Spacer - trunnion hanger 2	
24	890-00	Rubber bushing - trunnion hub	2
25	891-00	Trunnion hub - upper half, std.	2
26	898-00	Trunnion hub - lower half, std.	2
27	893-01	Trunnion tube	1
28	895-00	Washer - 7 GA x 4 1/32 ID x 5 1/8 OD	2
29	9639-03	U-bolt - 1.067 dia, 5 1/8 SQ	4
30	836-00	Hex nut (high) 1 1/8 - 12	8
31	837-00	Washer 1 1/8 plain	8
32	9640-00	Top plate - cast, SQ U-bolt	2
33	511-00	Bolt - 3/4 - 10 UNC x 3 LG	4
34	531-00	Hex nut - 3/4 - 10 UNC 2B	4
35	541-00	Lockwasher - 3/4	4
36	892-00	Trunnion hub - upper half, opt.	
37	835-04	U-bolt - 1.067 dia, 5 7/8 RD x 15 3/8	4
38	820-00	Bottom plate	2
39	847-08	Spring 25,000 lb. OS, 7 PL (opt)	
40	872-08	Spring 25,000 lb. US, 7 PL (opt)	

H-800B-60

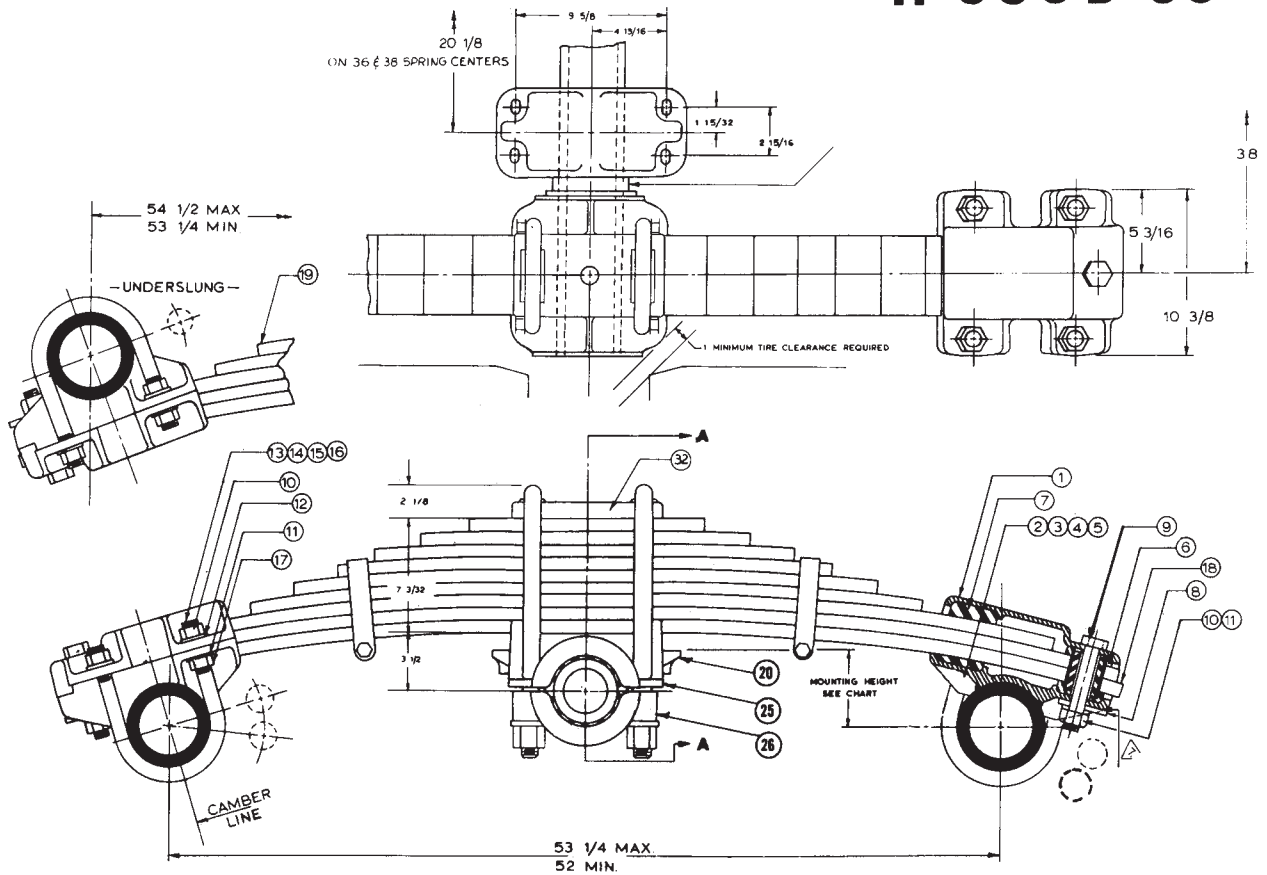

STD. TRUNNION MOUNTING & STD. 38 SPRING CENTERS SHOWN

PARTS LIST

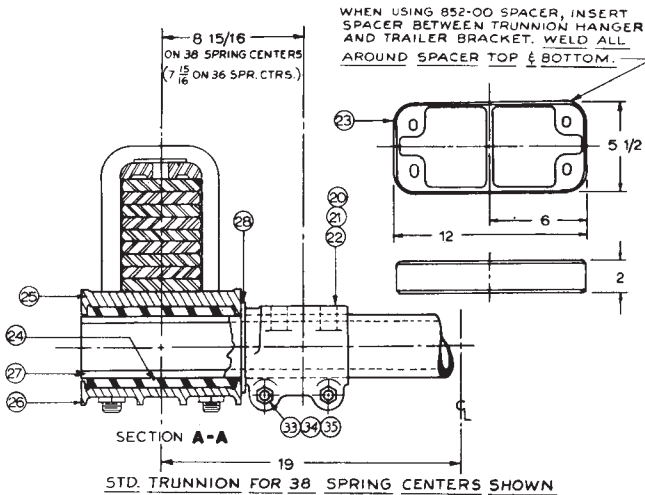

STD. TRUNNION FOR 38 SPRING CENTERS SHOWN

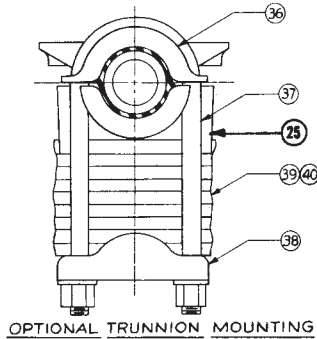

ITEM	NO.	DESCRIPTION	REQ.
1	805-01	Axle box - upper half	4
2	807-01	Axle box - lower half 5 RD	
3	807-02	Axle box - lower half 5 1/2 RD	4
4	807-03	Axle box - lower half 5 3/4 RD	
5	807-04	Axle box - lower half 6 RD	
6	813-00	Rubber pad with holes	8
7	814-00	Rubber pad without holes	8
8	816-00	Adjustment plate	4
9	719-03	Hex head bolt 1 - 14 x 5 3/8	4
10	736-00	Hex lock nut 1 - 14	20
11	9330-00	Lockwasher 1 shakeproof	12
12	774-01	Washer 1 plain	16
13	894-01	3/4 - 16 UNF 5 RD x 8 1/2	
14	840-02	U-bolt 1 dia, 5 1/2 RD x 9 3/8	8
15	840-03	U-bolt 1 dia, 5 3/4 RD x 9 5/8	
16	840-04	U-bolt 1 dia, 6 RD x 9 7/8	
17	870-00	Hex nut 1 - 14	8
18	848-00	Spring assembly 9 leaf (std)	2
19	873-00	Spring assembly 9 leaf US	
20	850-01	Trunnion hanger 2 1/2 high	2
21	849-01	Trunnion hanger 6 1/2 high	
22	897-01	Trunnion hanger 8 1/2 high	
23	852-00	Spacer - trunnion hanger 2	
24	890-00	Rubber bushing - trunnion hub	2
25	891-00	Trunnion hub - upper half, std.	2
26	898-00	Trunnion hub - lower half, std.	2
27	893-01	Trunnion tube	1
28	895-00	Washer - 7 GA x 4 1/32 ID x 5 1/8	2
29	9639-05	U-bolt - 1.067 dia, 5 1/8 SQ	4
30	836-00	Hex nut (high) 1 1/8 - 12	8
31	837-00	Washer 1 1/8 plain	8
32	9640-00	Top plate - cast, SQ U-bolt	2
33	511-00	Bolt - 3/4 - 10 UNC x 3 LG	4
34	531-00	Hex nut - 3/4 - 10 UNC - 2B	4
35	541-00	Lockwasher - 3/4	4
36	892-00	Trunnion hub - upper half, opt.	
37	835-05	U-bolt - 1.067 dia, 5 7/8 RD x 17	4
38	820-00	Bottom plate	2
39	848-10	Spring 30,000 lb. OS, 9 PL, (opt)	
40	873-10	Spring 30,000 lb. US, 9 PL, (opt)	

INSTALLATION INSTRUCTIONS

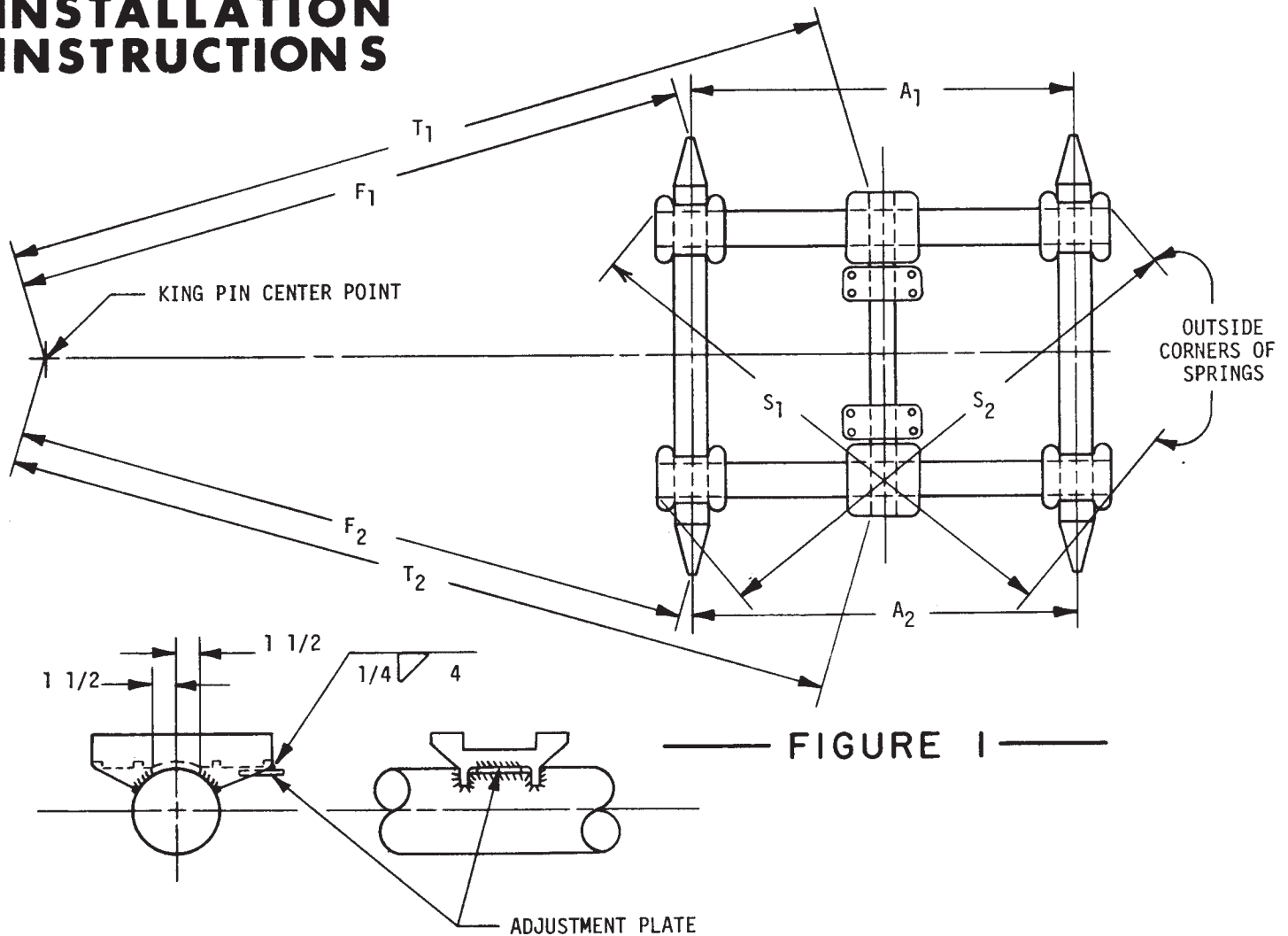

— FIGURE 1 —

— FIGURE 2 —

1. Refer to assembly drawings for detail component information, unit capacity, mounting height, and mounting dimensions. Before ordering suspension, it should be determined that there will be no interference between the desired H-800 single point suspension components and axle or brake components. See the proper assembly drawing for recommended camshaft location. Unless otherwise specified, springs will be pre-assembled on the trunnion tube at 38" spring centers.
2. Inspect suspension assembly to be certain that the spring alignment has not been destroyed during shipment. Disassemble the axle boxes and measure the distance between the full length leaves at each end to be certain that the springs are perpendicular to the trunnion tube, dimensions S₁ and S₂ (Fig. 1) must be equal. If spring alignment must be corrected, loosen trunnion hub section by backing off the nuts on the trunnion hub U-bolts approximately 2 revolutions. It may be necessary to use a hydraulic jack to reposition springs. With springs properly aligned, torque the trunnion hub U-bolts to 500 pound feet.
3. Locate axle centerline making sure that axle camber is up. The center of the axle may be located by measuring between the brake flanges and marking the center mid-way between. Place axle boxes (lower half) on axle equi-distant from centerpoint, with the same spacing as the suspension springs. To check this spacing, all axle boxes should measure the same distance from adjacent brake flanges. Tack axle boxes in place on axles and check with level to insure that boxes are parallel. (See Fig. 2) Weld axle boxes to axles using 3/8" fillet, weld around EXCEPT do not weld across top of axle-----stop weld 1 1/2" either side of vertical center line of axle bar.
4. Determine suspension location on trailer frame and measure from king pin to outside of frame on each side for proper alignment and mark frame for suspension centerline. Minimum frame reinforcement recommendations are illustrated in Figs. 3 and 4. Install mounting bracket if used and or prepare frame for bolting trunnion hanger. Refer to assembly drawing for bolting pattern. Frame mounting bolts are to be furnished by installer.

MOUNTING BRACKET IS ADJUSTABLE TO FIT 30 TO 40 FRAME WIDTH

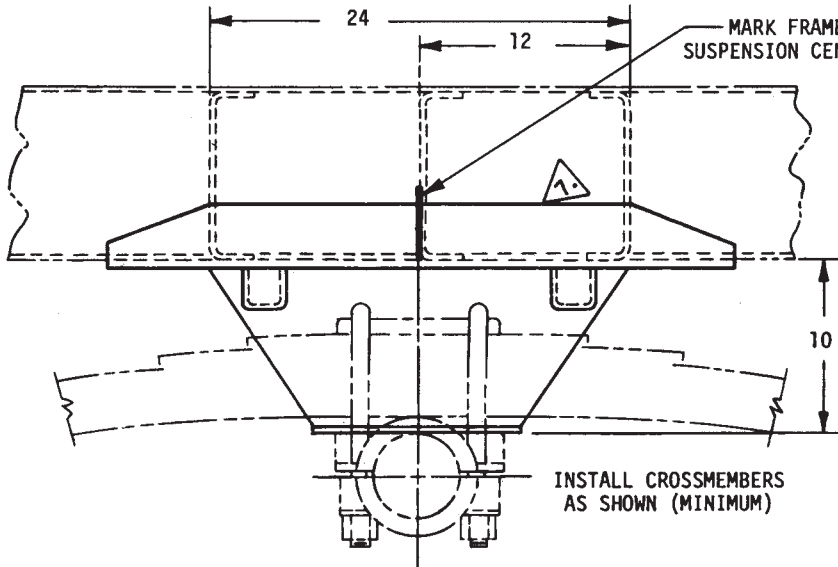

855-00 MOUNTING BRACKET
 OPTIONAL: INSTALL AS SHOWN. EIGHT, 5/8 DIA.
 BOLTS, NUTS AND WASHERS REQ'D. (NOT FURNISHED)

FIGURE 3

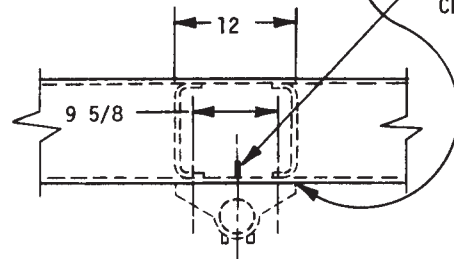
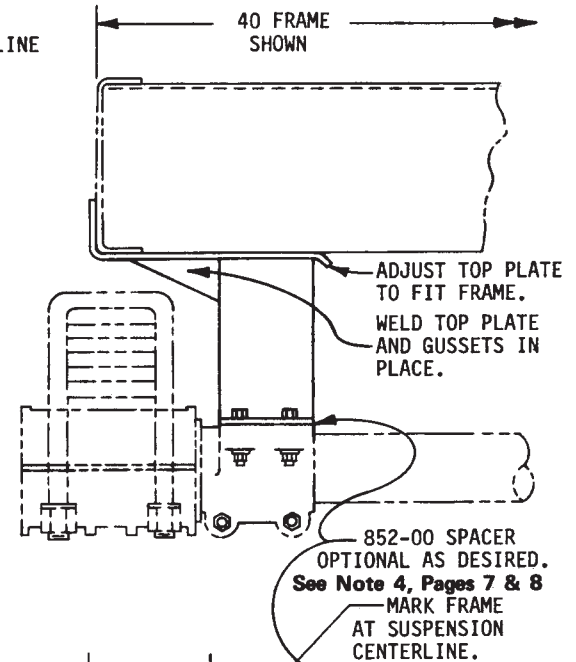

FIGURE 4

TORQUE RECOMMENDATIONS clean dry threads	
1 1/8-12 UNF U-bolt	500 pound feet
1-14 UNS bolt	350-375 pound ft.
3/4" - 16 UNF U-bolt	165-190 pound ft.
3/4" - 10 UNC bolt	150-175 pound ft.

Bolt trunnion hanger to mounting bracket or trailer frame. Do not tighten bolts. Align trunnion tube with king pin, see Fig. 1 Dimension T_1 and T_2 must be equal. Tighten 5/8" trunnion hanger bolts to 90 pound feet and re-check trunnion tube alignment. Weld trunnion hanger all around to mounting bracket or trailer frame. When using 852-00 spacer weld all around to trunnion hanger and frame member or mounting bracket. DO NOT STACK SPACERS.

- Assemble axle boxes to springs and axles, tightening fasteners only enough to hold components in place. If specific axle spacing is desired, position front axle so that its distance from the centerline of the trunnion tube is one-half the desired axle spacing. Align the front axle with the king pin so that $F_1 = F_2$, see Fig. 1. If the axle box fasteners are loose the axle may be moved forward or back at either end to accomplish alignment. Tighten the 1" diameter bolt and U-bolts sufficiently to prevent accidental mis-alignment. Align the rear axle with the front axle so that $A_1 = A_2$, see Fig. 1. Re-check alignment of both axles and if true alignment has been accomplished torque fasteners per torque recommendation chart. Weld adjustment plate (Fig. 2) to lower half of all four axle boxes using 4" long 1/4" groove weld on each axle box.

- Maximum allowable oscillation at trunnion hub should not exceed 15° above or below horizontal. Axle boxes are designed to accept bump-outs or stops which the installer should provide to assure tire clearance or to limit oscillation whichever becomes critical first.

Check all fasteners to be certain that they are torqued to the recommended level as shown in the above torque recommendation chart. Fastener torque should be checked after initial service and periodically thereafter.

- On the 60,000 lb. model with standard trunnion only, the 852-00 spacer must be included when ordering the 855-00 mounting bracket and 2 1/2" trunnion bracket

For applications or situations not covered in this section, contact Hutchens Industries, Inc., Engineering Dept.

